

TABULATED DATA FOR HYDRAULIC SHORING

Table 1 Hydraulic Shore Selection Guide (1)

Depth of Trench (ft)	Number of Cylinders	Hydraulic Cylinder Requirements					Sheeting
		Maximum Horizontal Spacing (ft)	Maximum Vertical Cylinder Spacing (ft)	Cylinder Size Width of Excavation (ft)			
				to 8	8 to 12	12 to 15	
Type "A" Soil							
0 to 6'	1	8'	4'	2"	2"	2" + OS2	Note 2
6' to 10'	2						
10' to 14'	3						
14' to 18'	4						
18' to 22'	5						
22' to 25'	6	7'-6"					
Type "B" Soil							
0' to 6'	1	8'	4'	2"	2"	2" + OS2	Note 2
6' to 10'	2	8'					
10' to 14'	3	7'					
14' to 18'	4	5'-6"					
18' to 22'	5	4'-6"					
22' to 25'	6						
Type "C-60" Soil							
0' to 6'	1	8'	4'	2"	2"	2" + OS2	Note 3
6' to 10'	2	6'-6"					
10' to 14'	3	5'					
14' to 18'	4	4'					
18' to 22'	5	3'-6"					
22' to 25'	6						

OS1 = 3" x 3/16" Wall Aluminum Oversleeve
 OS2 = 3.5"x3.5"x3/16" Wall Steel Oversleeve

Table 2 Allowable Sheeting

Plywood				Other Materials			
3/4" Finn Form				1" Thick steel plate 4' min wide x depth			
3/4" Omni Form				Steel sheet piling			
3/4" Plyform, APA B-B Class 1 Exterior				Aluminum Sheet piling			
3/4" HDO, APA High Density Overlay Exterior				Buildable box panels			
3/4" 14 Ply Arctic White Birch (Finland Form)							
1 1/8" CDX							
2 Sheets of 3/4" CDX (back to back)							
3/4" Combo Exterior Plywood							
3/4" Riga Form							
Timber Lagging Set Horizontal							
Thickness	Soil Type/ Span						
	A	B	C-60				
2"	4 ft						
3"	5 ft	4 ft					
4"	8 ft	6 ft	4 ft				
DF#2 or Oak							

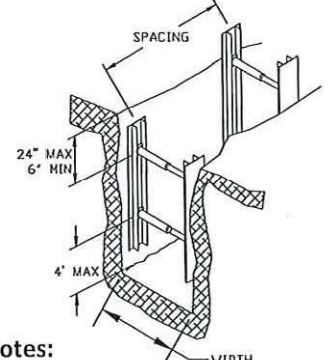

Notes:

- Soil shall first be classified in accordance with OSHA Appendix A Soil Classification for use with this selection guide. Type C-60 soil is OSHA Appendix A Type C soil that will stand up long enough to install the hydraulic shores.
- Sheeting is required at any depth wherever & whenever sloughing or raveling occurs. If sloughing or raveling occurs between sheeting, decrease spacing until it is prevented. See Table 2 for allowable sheeting. Sheeting may be attached to jack or set into trench separately.
- Sheeting is required at this depth.
- Sheeting must extend to the bottom of the excavation.
- This tabulation includes lateral loading from equipment weighing 20,000 lbs or less and a maximum 3 ft high spoil pile set back a minimum of 2 ft. The competent person shall determine the effect of all other surcharge loads and reduce hydraulic shore spacing as required to resist those loads.
- This Tabulated Data has been prepared by a Registered Professional Engineer as required to comply with the OSHA standard 29 CFR Part 1926 Subpart P, which assumes a 72 psf surcharge load.

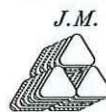

J.M. TURNER ENGINEERING, INC.
 CONSULTING ENGINEERS
 1325 COLLEGE AVE., SANTA ROSA, CA. 95404
 (707) 528-4503 FAX (707) 528-4505

Date:	Revised:	Job No:	Sheet No.:
12/30/14	9/25/2023	14157-1	1 of 4

Expires: June 30, 2024
 9/25/2023

DPNicoli

Superior Piling & Shoring Solutions

www.dpnicoli.com

Oregon

19600 SW Cipole Road
Tualatin, OR 97062
Phone: (503)692.6080
Fax: (503)692.1799

California

266 Harbor Way
San Francisco, CA 94080
Phone: (650)873.2999
Fax: (650)873.2988

Washington

3700 6th Avenue
South Seattle, WA 98134
Phone: (206)767.6080
Fax: (206)763.4088

Bay Point

1666 Willowpass Road
Bay Point, CA 94565
Phone: (925)432.6080
Fax: (925)432.6099

TABULATED DATA FOR HYDRAULIC SHORING

CONDITIONS FOR USE OF TABULATED DATA:

1. This Tabulated Data has been prepared by a Registered Professional Engineer as required to comply with the OSHA standard 29 CFR Part 1926 Subpart P, which assumes a 72 psf surcharge load. Equivalent to equipment weighing 20,000 lbs or less at 2' from the edge of the shoring wall.
2. HYDRAULIC SHORING must be used in a manner consistent with safe working procedures, Federal, State and Local regulations.
3. A "competent person", who has trained in the proper use of hydraulic shoring, safe excavation practices and soil classification must direct and control the use of the vertical hydraulic shoring system according to the spacing required in the depth chart.
4. The "Competent Person" must be knowledgeable and capable of complying with all federal regulations, state and local laws and ordinances.
5. The Soil Types A-25, B-45, are as defined in the OSHA standard. Soil Type C-60 is a moist, cohesive soil or a moist dense granular soil, which is not flowing or submerged. This soil can be cut vertically and will stand long enough to safely install the protective system.
6. The "competent person" must monitor the excavation for any signs of deterioration or condition change that may alter soil classifications.
7. "Competent person" is also one who is capable of identifying existing and predictable hazards in the surroundings or working conditions which are unsanitary, hazardous, or dangerous to employees, and who has authorization to take prompt corrective measures to eliminate them.
8. Any topic not covered by this data shall be governed by the OSHA Standard.
9. DP Nicoli shall not be liable for damage or injury resulting from improper use of the Hydraulic Shores. Improper use of, or modification to the Hydraulic Shores, or use of components not specifically authorized by DP Nicoli without the written consent of DP Nicoli shall void this data and all manufacturer's warranty.

DESIGN CRITERIA AND LIMITATIONS:

1. Depth and chart tables include a three-foot high spoil pile within a distance of 2' from the face of the excavation. Hydraulic Shores are not designed to support heavier surcharge loads, such as those imposed by building foundations. If Hydraulic Shores are used near building foundations, those foundations may need to be underpinned to prevent any settlement.
2. Hydraulic Shore struts are not designed to support any vertical loads and shall not be used as a ladder to provide access or egress to the trench.
3. The data is valid for Hydraulic Shores that are in structurally sound condition. Any significant damage will void this data, and all manufacturers' warranty. Any damaged Hydraulic Shores shall not be used.
4. The excavation and adjacent areas shall be monitored daily, after every rainstorm, and after every event that might change the stability of the excavation.
5. Surface water shall be diverted away from the excavation and water must be pumped out of the excavation bottom. The excavation shall be monitored in these conditions to prevent the water from generating excessive lateral pressure on the Hydraulic Shore.

NOTES FOR TABULATED DATA:

1. The top cylinder of the Hydraulic Shore shall be no less than six inches and no more than twenty-four inches below the top of the trench.
2. The lowest cylinder of a Hydraulic Shore shall be no more than forty-eight inches above the bottom of the excavation.
3. If sheeting is required, the sheeting shall extend from the top of the excavation to a maximum of two feet off the bottom of the excavation. Some soils may require that the sheeting be extended to the full depth of the excavation. (Maximum horizontal gap between sheets not to exceed 24" when sheeting is required)
4. When an Over sleeve is required, the Over sleeve shall extend the full collapsed length of the cylinder.
5. Trenches wider than 8' max require over sleeves. Utilize Efficiency's 2 in diameter hydraulic cylinders with standard or heavy duty extension system as required for desired excavation width. Trenches wider than 8 ft up to 12 ft (112 in - 144 in) require Efficiency's Steel or Aluminum Oversleeves that extend the full, collapsed width; or universal one-piece aluminum extension. Trenches 12 ft- 1 in up to 15 ft (145 in - 180 in) wide require Efficiency's Steel Oversleeves that extend the full, collapsed width.
6. If a Hydraulic Shore is positioned on a joint between two pieces of sheeting, the shore shall be spaced on the seam equally.
7. The Hydraulic cylinders shall be energized to maintain 750 psi. If the initial pressure cannot be maintained because the soil is too soft, another protective system will be required.
8. An approved shoring system shall consist of a minimum of two horizontally spaced Hydraulic Shores in trenches less than 12 ft long and 3 horizontally spaced shores in trenches greater than 12 ft long, spaced in accordance with this data, and the safe working area shall be 2 ft maximum beyond the last set of shores in a linear trench run if transitioning to a different type of protective system or far enough away from the end wall to be outside of the area of influence.
9. Trenches in Type A soil less than 7 ft wide do not require end shoring. Trenches in Type B soil less than 7 ft wide do not require end shoring. Trenches in Type C-60 soil less than 5 ft wide do not require end shoring. Workers shall stay in the safe working area which shall be between shores only. The competent person on-site is to address the condition at the ends of the trench and is to abide by the sheeting requirements if sloughing and/ or raveling occur.
10. Soil shall be classified in accordance with OSHA Appendix A or by a registered Civil Engineer prior to installing this equipment.
11. Surcharge load shall be determined by a competent person or Registered Civil Engineer.
12. Cylinder shall be pinned at each end and the connecting points shall not be allowed to translate in any direction, except when using universal extensions (per universal extension tab data).
13. The hydraulic system including pumps, hoses, and fittings used to pressurize cylinders shall have a safe working capacity of 1,000 psi.
14. Minimum of two, horizontally spaced, hydraulic vertical shores must be in place to classify the trench as shored.

This tabulated data applies to all hydraulic shoring and parts manufactured by, Cerda Industries Inc., Speed Shore Corporation, Efficiency Production, Inc., Pacific Shoring LLC, Pro-Tec Equipment, Cantel, Inc., All-Work Shoring, Safe-T-Shore and GME Corporation. Parts may be intermixed on the shore.



J.M. TURNER ENGINEERING, INC.
CONSULTING ENGINEERS
1325 COLLEGE AVE., SANTA ROSA, CA. 95404
(707) 528-4503 FAX (707) 528-4505

Date: 12/30/14	Revised: 9/25/23	Job No: 14157-1	Sheet No.: 2 of 4
-------------------	---------------------	--------------------	----------------------

Expires: June 30, 2024

9/25/2023

9/25/2023

9/25/2023

REVISIONS BY	
04/08/22 AV	
09/01/23 AV	
09/25/23 AV	

THIS TABULATED DATA APPLIES TO ALL HYDRAULIC SHORING AND PARTS MANUFACTURED BY CERUA INDUSTRIES INC., SPEED SHORE CORPORATION, EFFICIENCY PRODUCTION, INC., PACIFIC SHORING LLC, PRO-TEC EQUIPMENT, CANTEL, INC., ALLIED SHORING, SAFE-T-SHORE AND GME CORPORATION. PARTS MAY BE INTERMIXED ON THE SHORE.

DPNicolli

Superior Piling & Shoring Solutions

QUICK USE GUIDE
HYDRAULIC SHORING
TABULATED DATA



J.M. TURNER ENGINEERING, INC.
CONSULTING ENGINEERS
1325 COLLEGE AVE. SANTA ROSA, CA 95405
(707) 528-4503 FAX (707) 528-4504

SCALE: 1/8" = 1'
DATE: 12/30/14
DRAWN BY: A.A.B.
CHECKED BY: A.A.B.
DRAWING NO.: 14157-1/ST
SHEET: 3 OF 4

1 VERTICAL SPACING OF CYLINDERS

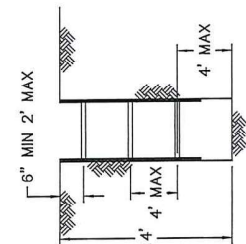

2 HORIZONTAL SPACING OF CYLINDERS

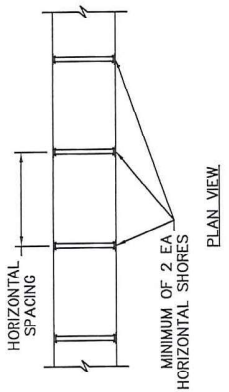

TRENCH SECTION

4 4" WIDE (TYP) FINFORM/PLYWOOD SHEETING

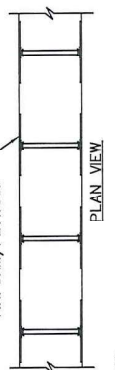

USE OF SHEETING:

- IN ALL CASES WHERE SLOUGHING OR RAVELING OCCURS, IF SKIPPED SHEETING DOES NOT PREVENT IT, DECREASE SHORE SPACING UNTIL IT DOES.
- TYPE C-60 SOIL
- MAXIMUM 2 FT ABOVE BOTTOM OF EXC. WHEN REQUIRED
- SHEETING TO EXTEND TO THE BOTTOM OF EXCAVATION IN B & C SOIL OVER 18' IN DEPTH OR WHEN SLOUGHING OR RAVELING OCCURS.

SHEETING

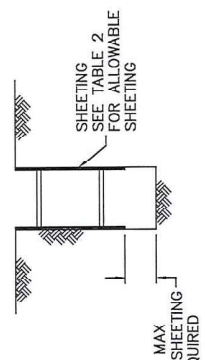

3 TRENCH WIDTH

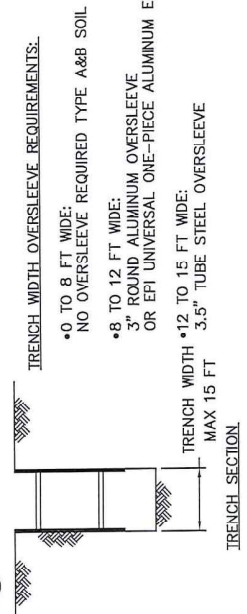

5 STACKED SHORES

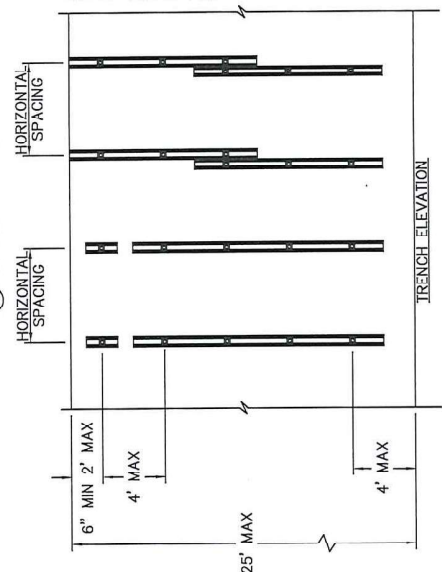

OK TO STAGGER RAILS PROVIDED HORIZONTAL SPACING IS NOT EXCEEDED
RAIL CAN BE USED VERTICALLY OR HORIZONTALLY SO LONG AS THE CYLINDER SPACING REQUIREMENTS ON TABLE 1 ARE MET AND THE LOWEST CYLINDER IS WITHIN 4' OF THE BOTTOM OF THE EXCAVATION.

6 SINGLE SHORE IN 6FT TRENCH

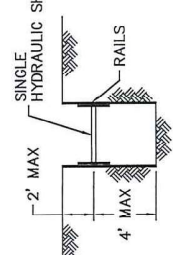

7 SLOPED TRENCH WITH HYDRAULIC SHORES

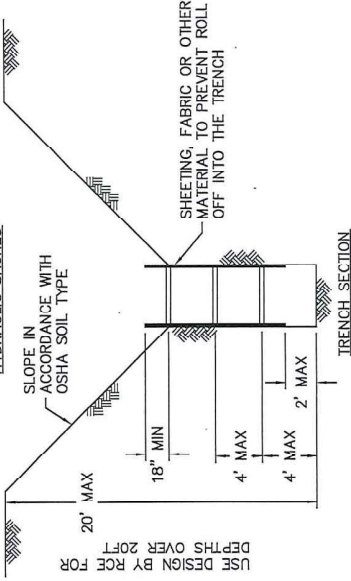

USE DESIGN BY ROR FOR DEPTHS OVER 20 FT



Expires: June 30, 2024

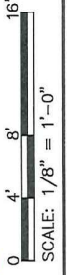

REVISIONS BY	04/08/22 AV
	09/01/23 AV
	09/25/23 AV

THIS TABULATED DATA APPLIES TO ALL HYDRAULIC SHORING AND PARTS MANUFACTURED BY, CERDA INDUSTRIES, INC., SPEED SHORE CORPORATION, EFFICIENCY PRODUCTION, INC., PACIFIC SHORING LLC, PRO-TEC EQUIPMENT, CANTEL, INC., ALLIED SHORING, SAFE-T-SHORE AND ONE CORPORATION. PARTS MAY BE INTERMIXED ON THE SHORE.

DPNicolli
Superior Piling & Shoring Solutions

DPNicolli
Superior Piling & Shoring Solutions

QUICK USE GUIDE
HYDRAULIC SHORING
TABULATED DATA

Superior Piling & Shoring Solutions
DPNicolli

J.M. TURNER ENGINEERING, INC.
CONSULTING ENGINEERS
1205 COLLEGE AVE. SUITE 1050A, CA. 95044
(707) 528-4903 FAX (707) 528-4904

SCALE: 1/8" = 1'
DATE: 12/30/14
DRAWN BY: A.B.B.
CHECKED BY: A.B.B.
DRAWING NO.: 14157-1/S2
SHEET: 4 OF 4

1 NON LINEAR TRENCH CONFIGURATIONS.

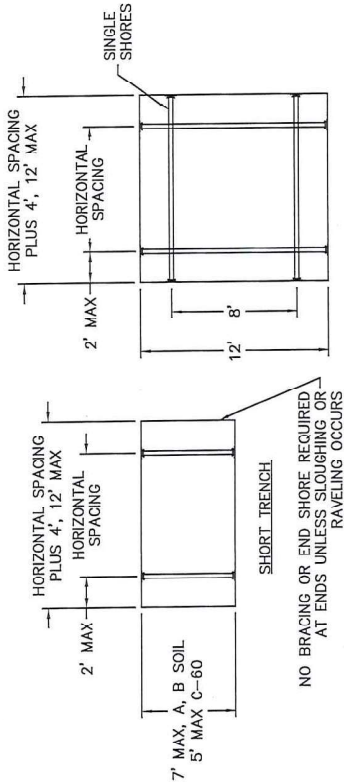

NOTES:

- WORKERS ALLOWED BETWEEN SHORES ONLY APPLIES TO BOTH DETAILS SHOWN ABOVE.
- SHEETING IS REQUIRED IF SLOUGHING AND/ OR RAVELING OCCUR
- IT IS ACCEPTABLE TO INSTALL THE TRENCH JACKS WITH SHEETING EITHER HORIZONTAL, VERTICAL OR DIAGONAL IN THE TRENCH AS LONG AS THE CYLINDER SPACING DOES NOT EXCEED THE MAXIMUM ALLOWABLE DISTANCE

2 CORNER AND T TRENCH CONFIGURATIONS.

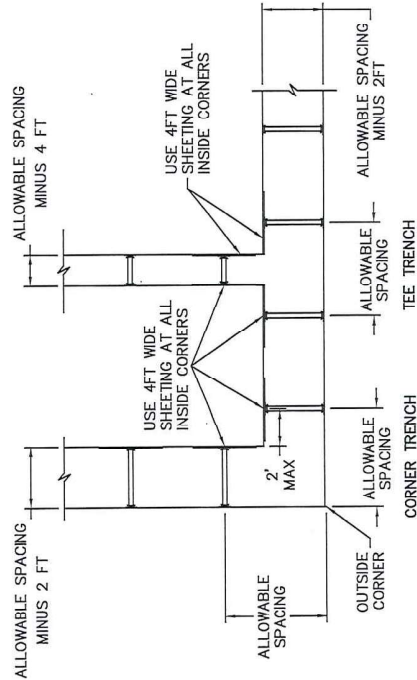

NOTE:
INSIDE CORNERS HAVE A STRESS CONCENTRATION AND WILL CRACK AND FALL OFF USE SHEETING TO PROTECT WORKERS

3 REMOVAL OF SOIL ARCH.

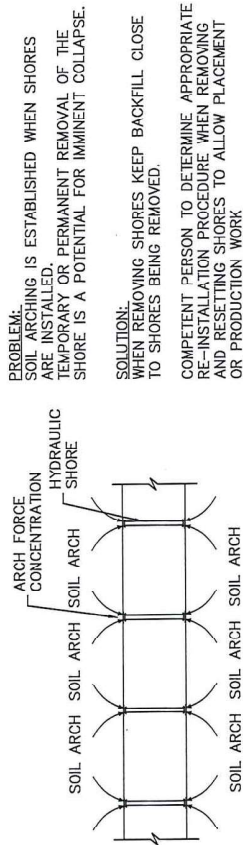

PROBLEM:
SOIL ARCHING IS ESTABLISHED WHEN SHORES ARE INSTALLED.
TEMPORARY OR PERMANENT REMOVAL OF THE SHORE IS A POTENTIAL FOR IMMINENT COLLAPSE.

SOLUTION:
WHEN REMOVING SHORES KEEP BACKFILL CLOSE TO SHORES BEING REMOVED.

COMPETENT PERSON TO DETERMINE APPROPRIATE RE-INSTALLATION PROCEDURE WHEN REMOVING AND RESETTING SHORES TO ALLOW PLACEMENT OR PRODUCTION WORK

CORNER AND T TRENCH ALTERNATIVE TO USING SHEETING AT INSIDE CORNERS.
NOTE: THESE CONFIGURATIONS PRESENT THE LIMITS OF EXCAVATION SIZES THAT CAN BE SHORED WITH HYDRAULIC SHORES.
MAINTAIN SOIL STABILITY BEHIND ALL CYLINDERS

